

## Industrial robot KUKA VK 30 with positioner 9-axis

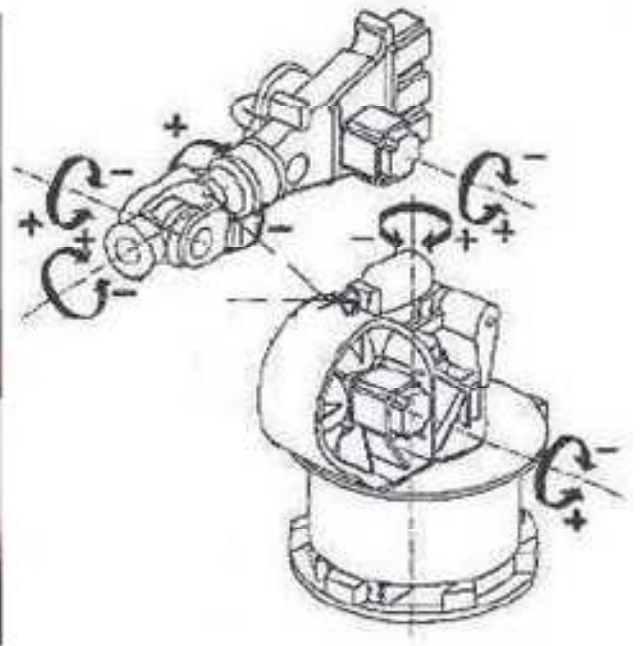

Product ID	Type of control	Year of construction	Lifting capacity	Working radius	Price	
KUKA V30	VRS1b	1996	30kg	2014mm	by request	
<b>Accessories</b>	Welding tool Fronius TPS330	32 digital inputs/outputs	2 analog outputs	Positioner with 3 axis. Table diameter: 500mm		
<b>Operating hours</b>						
	<b>Axis 1</b>	<b>Axis 2</b>	<b>Axis 3</b>	<b>Axis 4</b>	<b>Axis 5</b>	<b>Axis 6</b>
<b>Range of motion</b>	185°	-40° +93°	-210°+58°	350°	120°	350°
<b>Motion speed</b>	100 %/sec.	100 %/sec.	100 %/sec.	154 %/sec.	167 %/sec.	251 %/sec.

